

PSA Oxygen Generator .....

# Dual Topaz Plus



Specifically designed for reliability, energy efficiency, and ease-of-use, there are thousands of Topaz PSA Oxygen Generators currently in use throughout the world. Generating up to 18 LPM (38 SCFH) in a compact package, at up to 95.5% oxygen concentration, the Dual Topaz Plus is a great fit for a wide range of commercial applications.

## Features

- Self-contained (includes air compressors)
- Heavy duty metal enclosure
- Tank-mount design
- Advanced Engineering
- Ozone/high temperature process tubing
- Quick release fittings for ease of maintenance

## Typical Applications

### Manufacturing

- Cutting/Brazing/Soldering
- Thermal/Chemical Oxidation

### Environmental

- Ozone (Generator) Feed Gas
- Environmental Remediation
- Waste/Water Treatment

### Glass Industry

- Glass Work/Manufacturing/Blowing

### Additional

- Fish Farming

## Specifications

### Dual Topaz Plus

Product Characteristics	
Product Flow <sup>1</sup>	18 LPM (38 SCFH)
Product Pressure	20 psig (138 kPa)
Product Concentration (nominal)	93%
Product Dew Point	-100°F (-73°C)
Dimensions (W x D x H) (nominal)	40 x 19 x 47 in (102 x 48 x 119 cm)
Weight	265 lb (120 kg)
Physical Connection Product Gas Outlet	1/4" NPT-M/B-M size oxygen adapter
Ambient Operating Conditions	Locate the oxygen generator in a well-ventilated area that is protected from weather elements and remains between 40°F (4°C) and 112°F (44°C)
Control Power Requirements (Single Phase)	120 V ~ ±10%, 60 Hz, 10.0 A or 220 V ~ ±10%, 50 Hz, 5.0 A

<sup>1</sup> LPM (Liters per minute) gas measured at 1 atmosphere and 21°C / SCF (Standard cubic foot) gas measured at 1 atmosphere and 70°F

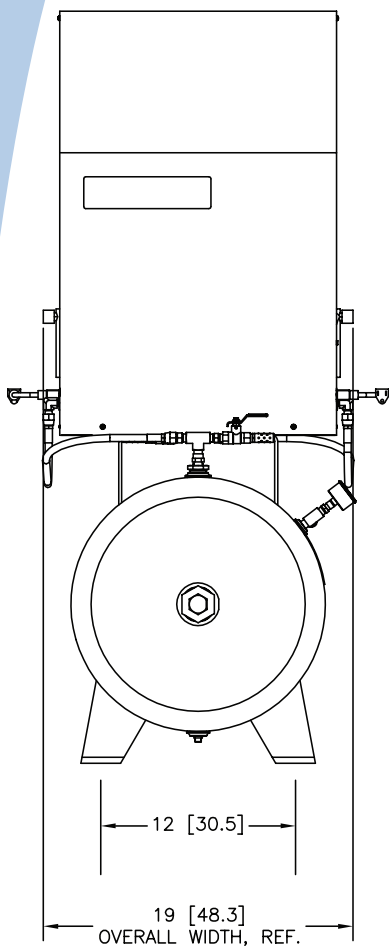

47 [119.4]  
OVERALL HEIGHT, REF.

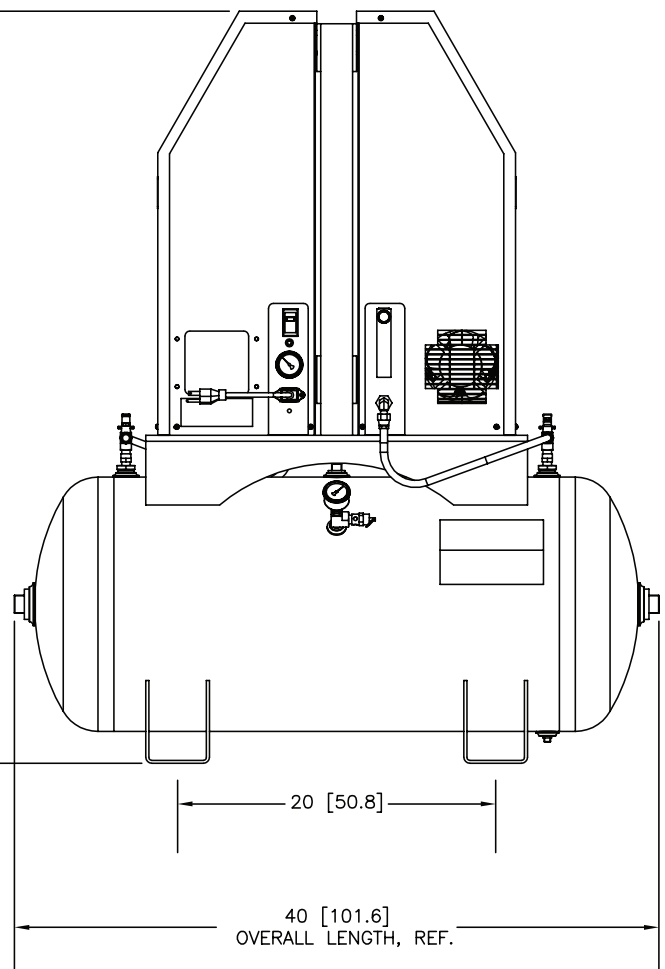

Note: All dimensions are nominal.

## Ordering Information

Model	Part Number	Description
Dual Topaz	AS116-1	120 V ~ ±10%, 60 Hz
Plus	AS116-2	220 V ~ ±10%, 50 Hz
Shipping Information		Dual Topaz Plus
Class		92.5
Commodity Classification Number		8421.39.8040
Dimensions (W x D x H)		48 x 40 x 59 in (122 x 102 x 150 cm)
Gross Weight		318 lb (144 kg) with Tank

### Warranty: 1 Year Parts and Factory Labor\*

\* An unprotected or inadequately ventilated environment, or improper control power may cause damage to the oxygen generator not covered under warranty.

All performance ratings based on an ambient temperature up to 100°F (38°C), up to 1,000 feet elevation, and 80% relative humidity.

Copyright (C) 2014 Chart Industries  
CAIRE Inc./Chart SeQual Technologies Inc./Chart Inc./AirSep Corp. reserves the right to discontinue its products, or change the prices, materials, equipment, quality, descriptions, specifications and/or processes to its products at any time without prior notice and with no further obligation or consequence.  
All rights not expressly stated herein are reserved by us, as applicable.

**AIRSEP®**

A Chart Industries Company

260 Creekside Drive

Buffalo, NY 14228-2075 U.S.A.

Tel: (716) 691-0202 • Fax: (716) 691-1255

www.airsepcpd.com • cpd@airsep.com

ML-IND0007 B