

S-218-GJC PUMP

Pump Performance (Nominal)

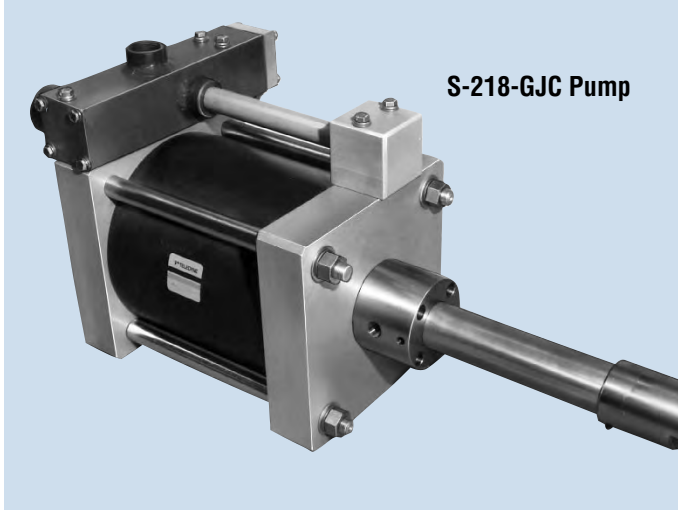

S-218-GJC Pump

S-218-GJC-()—This 10.5 hp, double-acting piston pump services oil, water and compatible chemicals. It is ideal for hydrostatic testing, machine operations, charging accumulators and for deep-hole applications.

Offered in three pumping ratios (45:1, 65:1 and 200:1), the S-218 pump produces medium to high pressures for controlled flow or for holding pressures. By regulating the air supply, liquid outlet pressure can be infinitely adjusted throughout the pump's pressure range.

Being air-driven, the pump is safe for use in hazardous areas. It can be used in a wide variety of temperatures and in other hostile environments. The standard pump uses a lubricated driving air supply.

Other features:

Pumps rapidly to desired pressure. Holds pressure indefinitely with minimal energy consumption, no increase in liquid temperature or parts movement. Automatically restarts to restore pressure balance when imbalance occurs.

Liquid pumping section materials are stainless steel and chrome-plated steel, both compatible with most non-abrasive liquids.

Air motor has water emitters to prevent water from collecting in humid conditions.

Can be driven with wellhead gases. Can operate in freezing or hostile conditions because of anti-icing device.

Safe for use in hazardous conditions because there are no electrical sparking problems or electrical connections.

S-218-GJC-45

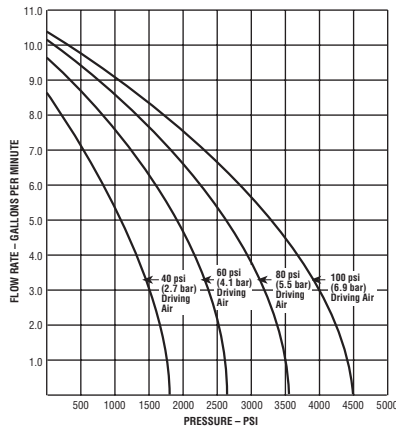

S-218-GJC-65

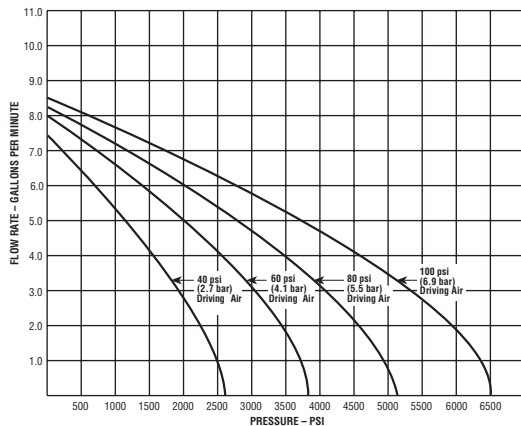

Model Numbers	S-218-GJC Pumps (45 & 65)
Length:	29 in. (73.6 cm)
Width:	10-5/8 in. (27.0 cm)
Height:	12-1/2 in. (31.8 cm)
Air Inlet Port:	1 NPT
Liquid Inlet Port:	1 NPT
Liquid Outlet Port:	1/2 NPT
Shipping Weight:	85 lbs. (38.6 kg)
Reference:	90226-1 90225-1

DISCHARGE CAPACITY—GALLONS (liters) PER MINUTE—APPROXIMATE
Based on 350 SCFM of driving air at 100 psi (9.9 Std. Cu. Meters driving air at 6.9 bars)

Pump Model No.	DISCHARGE PRESSURE									
	0 psi (0 bar)	500 psi (34.5 bar)	1000 psi (69 bar)	2000 psi (138 bar)	3000 psi (207 bar)	4000 psi (276 bar)	4500 psi (310 bar)	5000 psi (345 bar)	5500 psi (379.5 bar)	6000 psi (414 bar)
S-218-GJC-45 (45:1 ratio)	10.5 gal (39.7)	9.8 (37.1)	9.2 (34.8)	7.7 (29.1)	5.8 (22.0)	3.1 (11.7)	—	—	—	—
S-218-GJC-65 (65:1 ratio)	8.5 (32.2)	8.0 (30.3)	7.6 (28.8)	6.6 (25.0)	5.6 (21.2)	4.5 (17.0)	3.9 (14.8)	3.3 (12.5)	2.7 (10.2)	1.9 (7.2)