



## 71R/72R Series Twin Cylinder Vacuum Pump

### MODEL 71R645/71R655

28" HG MAX. VACUUM, 4.5 CFM OPEN FLOW (60HZ)

### MODEL 72R547/72R555 STAGED

29" HG MAX. VACUUM, 2.6 CFM OPEN FLOW (60HZ)

### MODEL 72R645/72R655

28" HG MAX. VACUUM, 5.5 CFM OPEN FLOW (60HZ)

#### PRODUCT FEATURES

- Oilless operation
- All wetted aluminum parts treated for corrosion protection from moisture
- Rugged motor shell construction

#### INCLUDES

- Dry-cell capacitor AT250 (D303X Motors, AT251 (D304X Motor) - not pictured, shipped unattached
- Rubber feet (4) AF713A

#### Product Dimensions (Inches, mm)

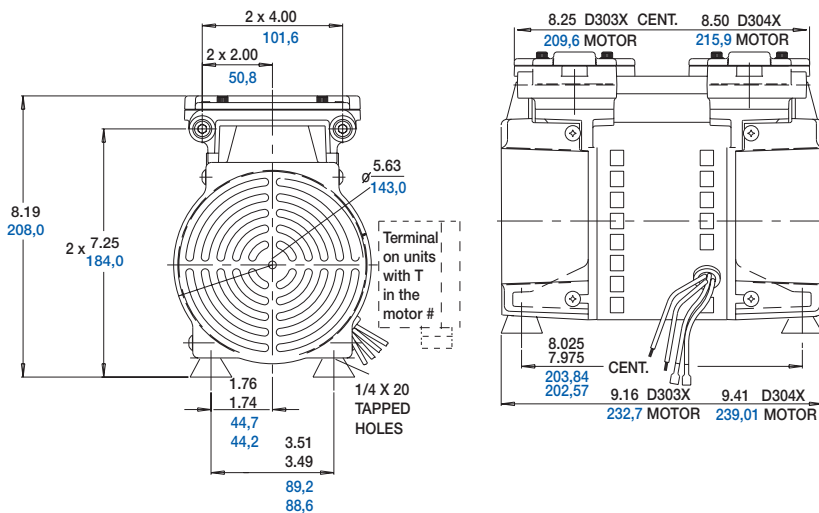



Model Number	Motor	Motor Type	Parallel/ Staged	RPM		HP	kW	Wt.	
				60 Hz	50 Hz			lbs.	kg
•71R645-V114-D303X	115-60-1	PSC (4 pole)	Parallel	1650	--	1/3	0,25	15.6	7,09
•71R655-V114-D304X	220-240-50-1	PSC (4 pole)	Parallel	--	1425	1/3	0,25	16.0	7,27
•72R547-V116-D303X	115-60-1	PSC (4 pole)	Staged	1650	--	1/3	0,25	15.6	7,09
•72R645-V114-D303X	115-60-1	PSC (4 pole)	Parallel	1650	--	1/3	0,25	15.6	7,09
•72R655-V114-D304X	220-240-50-1	PSC (4 pole)	Parallel	--	1425	1/3	0,25	16.0	7,27

•Units shipped with capacitor - unattached

### Product Performance (U.S./Imperial, Metric)

