

PowerStar® 4

Operation and Service Handbook



Sprague® Products

Division of Curtiss-Wright Flow Control Corporation

10195 Brecksville Road, Brecksville, Ohio 44141 • 440/838-7690 • FAX: 440/838-7513 • www.cwfc.com

Napoleon House, Gore Cross Business Park, Corbin Way, Bridport, Dorset DT6 3UX UK Tel: 44 (0) 1308 422256, Fax: 44 (0) 1308 427760

ISO 9001:2000



Registered Company



TUV Rheinland
of North America

INTRODUCTION

This handbook provides the necessary information to install, operate, service and overhaul the **PowerStar™4** series pumps.

HOW THE PowerStar™4 AIR-DRIVEN PUMP WORKS

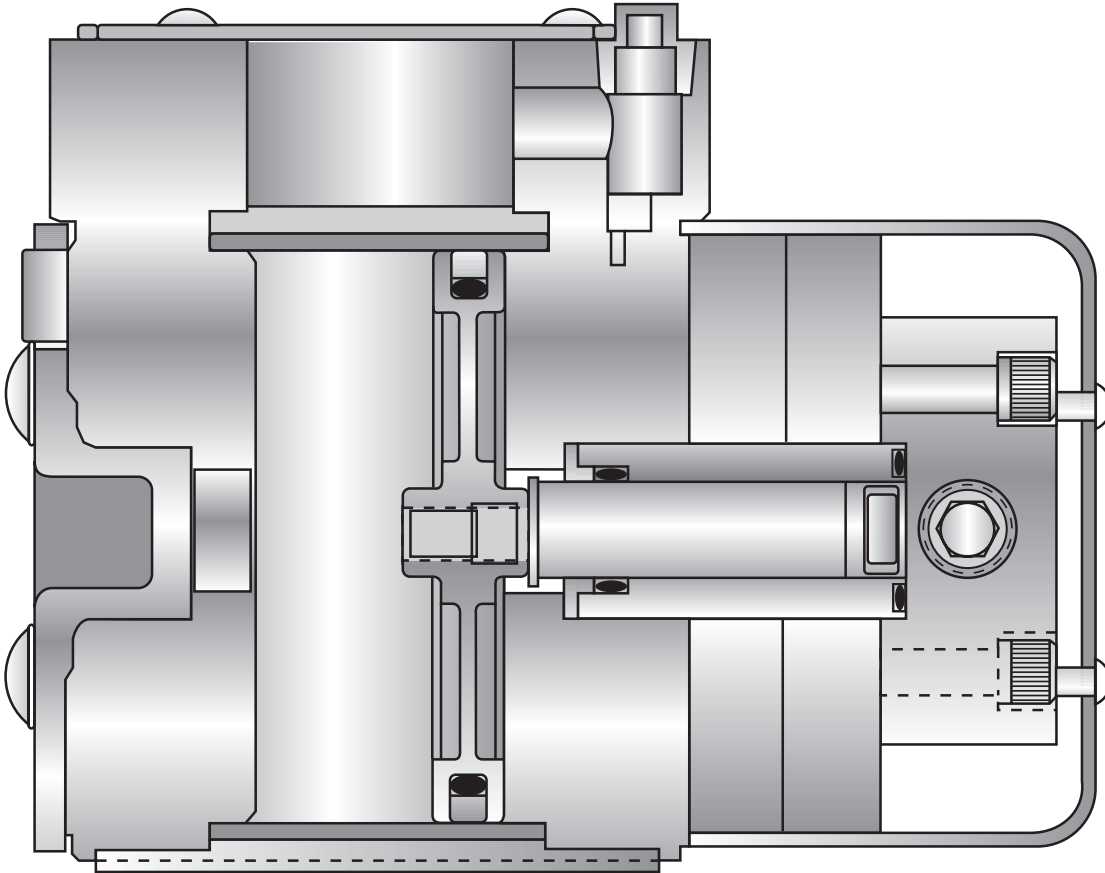

The **PowerStar™4** pump develops high out put pressures by applying the principle of differential areas. The pump has a large area air piston, air driven at low pressures. This air piston drives a small area liquid piston that in turn pumps liquids at high pressures.

The liquid output pressure is determined by the ratio between the area of the air drive piston, the area of the liquid piston and the applied operating air pressure. In double ended pumps, this pressure will be increased by the pressure of the liquid entering the pump if any and decreased by the area of the piston rod.

The area relationship of the air to liquid piston is referred to as the nominal pump ratio. The pump ratio is indicated in the part number following the air module number (P4).

Example: P45 pump has an approximate ratio of 5 to 1. Or the pump generates 5 psi liquid pressure for every 1 psi air pressure.

In operation, the P45 pump using 100 psi of input air pressure will produce an approximate maximum liquid output pressure of 500 psi, 80 psi air will produce approximately 400 psi, 60 psi will produce approximately 300 psi, and 40 psi will produce approximately 200 psi. **NOTE:** Pump pressures will vary according to lubricity of liquids being pumped and local conditions.

The liquid output pressure can be infinitely adjusted throughout the pump's range by regulating the incoming air pressure.

1.0 INSTALLATION

- 1.1 The **PowerStar™4** pumps require only attachment to a mounting surface and plumbing connections of three lines:
- From clean driving air source to pump air inlet port.
 - From clean liquid source to pump liquid inlet port.
 - From pump liquid outlet port to working system.

WARNING:
**FOR MAXIMUM PUMP LIFE, DRIVING AIR
SHOULD BE FILTERED TO 10 MICRON.
LIQUID RETURN SHOULD BE FILTERED TO 5 MICRON.**

WARNING:
**LOOSE CONNECTIONS WILL RESULT IN HIGH PRESSURE LEAKS AND
CAN CAUSE SERIOUS INJURY OR DEATH.**

WARNING:
**DO NOT EXCEED 100 PSI DRIVING AIR PRESSURE. PRESSURES IN EXCESS
OF 100 PSI CAN CAUSE EQUIPMENT DAMAGE AND SERIOUS INJURY
OR DEATH IN THE EVENT OF AN EXPLOSION.**

To obtain effective liquid sealing at the inlet and outlet ports of the pump the NPT male threads of the two liquid lines connecting to and from the pump should each be sealed with two wraps of TEFLON® tape.

Note: Tape to within one or two threads of the end of the fitting **NOT** to the end. High pressure ratios 114:1, 203:1 and 333:1 utilize 9/16-18NBS connections at the liquid outlet port and do not require TEFLON® tape, do not use pipe dope or other sealant. No special tools are required to install the pump.

- 1.2 **LOCATION** - For maximum performance, the pump's liquid inlet port should be below the liquid level in the reservoir. However the pumps may be mounted on top of the reservoir for convenience.
- 1.3 **MOUNTING** - Four mounting holes are provided in the pump bracket for attachment to the mounting surface.
- 1.4 **PLUMBING** - All plumbing must be rated to at least 1-1/2 times maximum operating pressures.
- Connect driving air supply line to pump air inlet port.
 - Connect liquid supply line from reservoir to pump inlet check valve.
 - Connect system liquid line to pump outlet.

For line hook-up to pump, pump installation within hydraulic circuit and recommended accessories, see Figure 1-1.

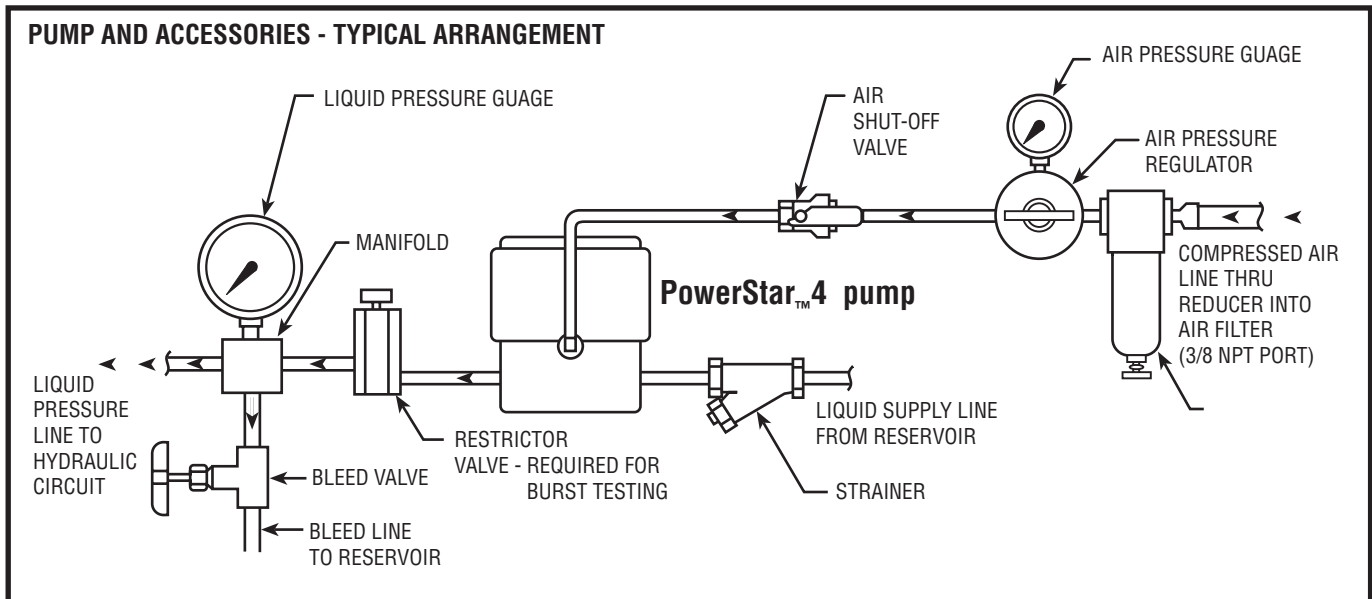

Figure 1-1, Pump installed in a typical circuit with recommended accessories which are available from Sprague Products.

2.0 OPERATION

2.1 START PUMP

- a. Close air shut-off valve between pump & pressure regulator.
- b. Turn on driving air supply.
- c. Adjust air pressure regulator at air control unit (Filter Regulator) to 20 psi (1.4 Bar) starting pressure.
- d. Open valve in hydraulic circuit to allow free liquid flow.
- e. Slowly open the air-shut-off valve to start the pump cycling. Reduce air pressure to 10 psi (.69 Bar)
- f. After the pump has been primed, close valve in hydraulic circuit. Note: High pressure pumps may require positive pressure at liquid inlet to prime.
- g. Check hydraulic and air circuits for leaks in lines, fittings and etc.
- h. With pump and circuit operating properly, readjust air pressure regulator until desired pump discharge pressure is reached. The hydraulic circuit is ready to operate.

2.2 STOP PUMP

- a. Close air shut-off valve. Normally after driving air supply has been adjusted, the pump can be on-off controlled or reduced in pumping rate at the air shut-off valve.
- b. After stopping pump, bleed off hydraulic pressure before disconnecting the hydraulic circuit.

3.0 MAINTENANCE

- 3.1 **SPECIAL TOOLS** - None are required to service pump. Use standard tools.
- 3.2 **INSPECTION AND MAINTENANCE** - Refer to Chart 3.1 as a guide to general maintenance. Recommended inspection periods may require adjustment to comply with local conditions or as determined by experience.
- 3.3 **TROUBLE SHOOTING** - Chart 3.2 aids in checking the pump and outlines corrective action. To eliminate the unnecessary disassembly of the pump, probable causes of malfunction are listed in the following order:
- a. Causes that can be corrected without disassembly of the pump.
 - b. Causes that can be corrected with partial disassembly of the pump.
 - c. Causes that require complete disassembly of the pump.

The number in parenthesis following the part name corresponds to the item number on the **PowerStar™4** Illustrated Parts Breakdown (IPB).

- 3.4 For disassembly, inspection, repair and reassembly of the **PowerStar™4** pump, refer to Sections 4.0, 5.0, 6.0 and 7.0 following.

ITEM	INSPECTION PERIOD	REQUIRED MAINTENANCE
(1) Driving Air Filter	10 hours	Check for and drain liquid accumulated in filter from condensation.
	50 hours	Check filter element and other components for clogging. Clean as required.
(2) Driving Air Pressure Regulator	Periodic	Check for air leaks and repair as required.
(3) Driving Air Pressure Gauge	10 hours	Shut-off inlet air pressure and check for zero reading.
	50 hours	Calibrate against master gauge.
(4) Pump	10 hours	Check pump and fittings for air or liquid leakage. Repair as required.

Chart 3.1, Schedule of inspection and maintenance.

TROUBLE	PROBABLE CAUSE	CORRECTION
(1) PUMP IS NOT DELIVERING FLUID (pump running)	(a) Reservoir fluid supply is low. (a) Fluid supply line to pump inlet check valve is clogged.	Add fluid as required. Remove and clean line. Check reservoir, its inlet filter and outlet for accumulation of foreign matter. Clean as required.
(2) PUMP IS NOT DELIVERING FLUID (Pump not running)	(a) Driving air supply disconnected air shut off valve closed or air filter clogged (a) Air press regulator not adjusted. (b) Air shuttle valve sticking. (b) Air pilot valves damaged or sticking. (b) Air pilot valve springs broken.	Reconnect line. Open valve. Clean air filter. Adjust regulator. Remove and clean air shuttle valve assembly. Remove and clean or replace as required. Replace.
(3) PUMP RUNNING RAPIDLY FLUID FLOW IS REDUCED (short cycling)	(b) Air pilot valves damaged or sticking. (b) Air pilot valve O-ring damaged. (b) Air pilot valve springs broken. (b) Air shuttle valve manifold seals damaged or missing. (b) End plate air seals damaged or missing.	Remove and clean or replace. Replace. Replace. Replace. Replace.
(4) PUMP FAILS TO GENERATE FLOW FLOW IS REDUCED	(b) Leakage or blockage at inlet or outlet check valves. (b) Damaged high pressure seal, piston or cylinder.	Remove and clean check valves. Look for foreign matter lodged in seating areas. Replace.
(5) HYDRAULIC FLUID IN EXHAUST AIR	(b) Damaged high pressure seal.	Replace.
(6) AIR IN SYSTEM	(a) Air leak in suction line or low liquid level.	Repair suction line or fill reservoir.

Chart 3.2, Trouble-shooting pump operation

4.0 DISASSEMBLY

4.1 This procedure describes the removal of the air module from the fluid module and complete disassembly of the pump. The number following the part name in parenthesis corresponds to the item number in the **POWERSTAR™ 4** Illustrated Parts Breakdown (IPB) on page 14.

When the pump is disassembled, air and liquid modules should be kept together and handled carefully to avoid damage to precision machined surfaces.

To wash metal parts, use Stoddard dry cleaning solvent per Federal Specification P-D-680 of MIL-F-7024, Type II or use any quality commercial solvent that is available.

The pump disassembly and reassembly can be done with the following standard hand tools:

- a. Phillips head screwdriver
- b. Blade type screwdriver
- c. Ratchet wrench with 5/8" Dia. extension hex socket.
- d. Standard allen wrench set.
- e. Small adjustable wrench.
- f. Retainer ring pliers.

Power equipment and special tools can be used at user's discretion.

- 4.1.1 Unscrew the three round head screws (74) to remove the muffler enclosure (40). Repeat this procedure for double ended pumps.
- 4.1.2 Unscrew the four socket head screws (42) to remove the lockwashers (41), high pressure plate (48) and muffler media (75). Repeat this procedure for double ended pumps. Note: Muffler media is used in only one side of the double ended pumps.
- 4.1.3 Remove high pressure cylinder (44) by gently rocking and pulling outward. Use caution to prevent damaging cylinder, piston or mating surfaces. Repeat this procedure in double ended pumps.
Note: To replace high pressure seal only go to step 7.1.
- 4.1.4 Remove four truss head screws (14) to remove air motor plug (10). Single ended pumps only.
- 4.1.5 Insert 5/8" socket through port in end plate (2) engaging hex connection on air piston (4). Use adjustable wrench on the flats of the liquid piston rod/piston (45) and turn counterclockwise to remove. Double ended pumps: Repeat procedure except grasp each piston rod/piston by the wrench flats, remove one side then repeat the process.
- 4.2 Use bench vise to hold high pressure plate while assembling and disassembling. Cushion vise jaws with soft aluminum plates to prevent scratching high pressure plate.
 - 4.2.1 Outlet check valve removal. For ratios 5:1 and 10:1: remove retaining ring (62) with snap ring pliers. For ratios 21:1, 34:1 and 64:1: remove retainer (61) with Allen wrench, and then remove ball (58), ball guide (59), and spring (60). Ratios 21:1, 34:1 and 64:1 have a Teflon seat (57) in the high pressure plate under the ball of this port. Check to be sure it is present and undamaged.
Inlet check valve removal. For ratios 5:1, 10:1, 21:1, 34:1 and 64:1: remove check seat valve (50) with Allen wrench, and then remove ball (53), ball guide (54), and spring (55).
For ratios 114:1, 203:1 and 333:1, the check valves are removed through the inlet check valve port. Remove the inlet check valve seat (64) with an Allen wrench, then remove the ball (66), guide (67), spring (68), and seat (69). Use a long (2 1/2" or longer) 8-32 bolt to remove seat (69). Use item 12 from the air motor if an 8-32 bolt is not available.
Repeat this procedure for double-ended pumps.

This completes disassembly of the liquid module.

- 4.3 Remove truss head screws (19) 12 places to remove enclosure (28) and O-rings (17) 2 and (18) 2.
- 4.3.1 Remove socket head bolts (12) 2 ea. & (15) 4 ea.
- 4.3.2 Gently tap housing assemblies (1) and (2) with leather or rubber mallet to remove from air cylinder (3) and air valve assembly (8) taking care not to lose O-rings (29) and (22) or damage air valve assembly (8). Remove air piston (4) and seal system (21) from air cylinder (3).

This completes disassembly of the air module

- 4.3.3 Remove plug (9), spring (6), piston (5) and O-ring (7) from end plates (1) and (2). Rotate plate and using a small blade type screwdriver, remove push-on ring (26). Using an O-ring removal tool remove O-ring (24).

5.0 CLEANING AND INSPECTION

**WARNING:
NO PARTS REWORK ALLOWED.
USE ONLY GENUINE SPRAGUE PRODUCTS REPLACEMENT PARTS.**

- 5.1 Remove remaining O-rings from sub-assemblies and wash all metal parts in solvent with the exception of air valve assembly (8). Dry parts thoroughly with soft lint free cloth or clean compressed air.
- 5.2 Check air valve assembly (8) for free movement and cleanliness. If contaminated, air valve may be soaked in filtered kerosene to remove contamination and air dried. If free movement is not restored, air valve must be replaced.
- 5.3 Inspect all parts under a strong light for any evidence of distortion (springs), cracks, pitting, scoring or galling.
- 5.4 Inspect all threaded parts for chipped, crossed or stripped threads.
- 5.5 Inspect inlet and outlet check balls and seating areas for nicks, scratches, burrs, excessive wear or corrosion.

6.0 REPAIR AND REPLACEMENT

- 6.1 Polish metal parts to remove minute imperfections, minor cratches or scoring. Use wet-or-dry paper grit # 600.
- 6.2 Fluid piston (45) and cylinder (44). Carefully polish piston to remove minor scratches or nicks. Use grit # 600. Polish cylinder with hone to remove minor imperfections. Use a very fine polishing stone. Replace piston and cylinder if there is any evidence of galling or if imperfections cannot be easily removed.
- 6.3 Clean all repaired parts in solvent as described in paragraph 5.1 preceding.
- 6.5 Replace all metal parts that fail to pass inspection or are damaged or worn beyond simple repair.
- 6.6 Replace all O-rings, seals, seal retainers and springs at each overhaul. Overhaul kits from Sprague Products contain all the necessary parts to properly overhaul the pump.

7.0 REASSEMBLY

Before reassembling pump, wash metallic parts thoroughly in solvent and dry. Pump should be assembled on a clean work bench in a dust free area to prevent contamination.

- 7.1 Reassemble end plates (1) and (2) by installing O-ring (24) and push-on ring (26) with a straight steel pin.

Install O-ring (7) on pilot valve piston (5). Lightly lubricate pilot piston with Vaseline, hydraulic oil or petrolatum per Federal Specification VV-P-236 and insert in pilot valve port in end plates(1) and (2). Insert spring (6) over pilot valve piston (5). Install O-ring (17) on plug (9)and thread into port in end plate over spring. Torque 30 to 40 inch pounds. Install O-rings (27) onto end caps (1) and (2).

- 7.2 Install seal system (21) onto air piston (4). Note: Seal may be heated by immersion in hot water to facilitate installation. Insert air piston/seal assembly into air cylinder (3).

- 7.3 Install air piston/seal/air cylinder onto end plate (1) assembly.

- 7.4 Lubricate seal (29) with petrolatum jelly to hold in place and install in O-ring groove on gasketed side of air valve (8).

- 7.5 Place end plate (1) on bench with cylinder facing up and place air valve (8) gasketed side down over ports in end plate making sure that gasket guides fit into holes in end plate (1) and O-ring (29) is in position.

- 7.6 Lubricate seal (22) and (29) and place in O-ring grooves in air valve (8).

- 7.7 Place end plate (2) over cylinder (3) and air valve (8) and press down to engage. Install socket head bolts (12) and tighten hand tight.

- 7.8 Rotate air motor to an upright position and install bolts (15) and nuts (16). Torque to 120 inch pounds. Torque bolts (12) to 20 inch pounds.

- 7.9 Lubricate O-rings (17) 2 and (18) 2 and place in grooves in end plates (1) and (2). Place enclosure (28) over air module and fasten top first with 4 screws (19). Torque to 20 inch pounds. Install remaining screws (19) 8 ea. in side panels and torque to 10 inch pounds.

- 7.10 Insert a 5/8" socket through hole in end plate (2), engaging hex connection on air piston (4). Neither ratio 5:1 nor 10:1 uses a seal retainer. For ratios 21:1 and 34:1, slide spacer (43) over piston rod (45). For ratio 64:1, slide spacer (43) over piston (63). Screw piston rod (45) into air piston (4) using adjustable wrench on the flats of the liquid piston rod (45). Torque to 120 inch pounds. If torque patch on piston rod (45) is worn, piston may be secured by using a drop of Loctite® on the thread. Position seal spacer in hole of air motor end plate (1).

Install seal (46) onto piston (63) when assembling 5:1, 10:1, 21:1, and 34:1 ratio pumps. For the 64:1 ratio pump only: install seal (46) on piston (63) and fasten seal retainer (77) with screw (78) to piston (63). For ratios 114:1, 203:1, and 333:1, install piston (45) to air piston (4) of air motor. Torque to 60-75 in-lbs. Lubricate piston with light coating of petrolatum jelly or equivalent. Slide spacer/retainer (43) over piston (45) and depress into endplate bore (1) of air motor. Slide piston seal (46), backup ring first, and then the u-cup seal (open end of u-cup seal facing unthreaded end of piston) over the piston (45) up to the spacer/retainer (43). Install piston guide (80) to groove of piston (45). Lubricate internal diameter of high pressure cylinder (44) with light coating of petrolatum jelly or equivalent. Carefully slide piston (45) into cylinder (44) and then guide seal (46) and retainer (43) into seal cavity of cylinder (44).

Note: Double-ended models require installation of separator kits to prevent back pressure to high pressure seals. To rebuild the separator kit, refer to the separator kit illustrated parts breakdown on page 12. Carefully remove the O-rings (2,3) from the separator retainer (1). Clean and inspect separator retainer as instructed for all parts in 5.1 and 5.3. Install new O-rings (2,3) in separator rebuild kit into separator retainer (1). For installation of separator kits, refer to page 13.

7.11 Assemble inlet and outlet check valves into high pressure plate as detailed in the reverse of 4.2.1.

7.12 Lubricate O-ring (47) and backup ring (79) with petrolatum jelly or equivalent, and install into circular groove of high pressure plate (48).

7.13 For 5:1, 10:1, 21:1, 34:1 and 64:1 ratio pumps. Lubricate and install O-ring (47).

Place high pressure plate (48) and check valve assembly over high pressure cylinder, making sure that outlet check valve is properly oriented. Attach high pressure plate (48) to cylinder, using screws (81) and lock washers (82). Torque to 18-20 in-lbs. Install screws (42) and lockwashers (41) through high pressure plate (48) and attach to air motor plate (1). Place alignment spacer (P/N 93747-1 for 5:1 and 10:1 ratio pumps, and P/N 93747 for 21:1, 34:1 and 64:1 models) between air motor plate (1) and high pressure plate (48).

As the screws (42) are diagonally tightened to 100 inch pounds, make sure that the high pressure plate (48) remains parallel to the air motor plate (1) by checking the spacer. The spacer must remain free and not become stuck or wedged between the high pressure plate (48) and the air motor end plate (1) as the screws (42) are tightened. Remove the spacer when tightening of the screws has been completed. See illustration on page 11.

For 114:1, 203:1 and 333:1 ratio pumps. Install studs (42) completely into air motor plate (1). Lubricate and install backup ring (79) and O-ring (47) into groove of high pressure plate (48). Place high pressure plate (48) and check valve assembly over high pressure cylinder (44) and studs (42), making sure that the outlet check valve is properly orientated. Attach high pressure plate (48) to cylinder (44), using screws (81) and lockwashers (82). Torque 18-20 in-lbs. Install heavy hex nuts (83) and lockwashers (41) over studs (42) and torque diagonally to 100 in-lbs.

7.14 Install muffler media over screws (42) and cylinder (44) between high pressure plate (48) and air motor module.

7.15 Install muffler enclosure (40) with three round head screws (74) and tighten to 10 inch pounds. Repeat this process for double ended pumps.

7.16 Install air motor plug (10) with four truss head screws (14) and tighten to 5 inch pounds.

This completes pump assembly

8.0 INSTALLATION & TEST

8.1 Install pump into hydraulic circuit and test per section 2.0 paragraphs 2.1 & 2.2.

**ASSEMBLY OF HIGH PRESSURE PLATE TO AIR MOTOR
ASSEMBLY UTILIZING PART NO. 93747 SPACER**

Top View

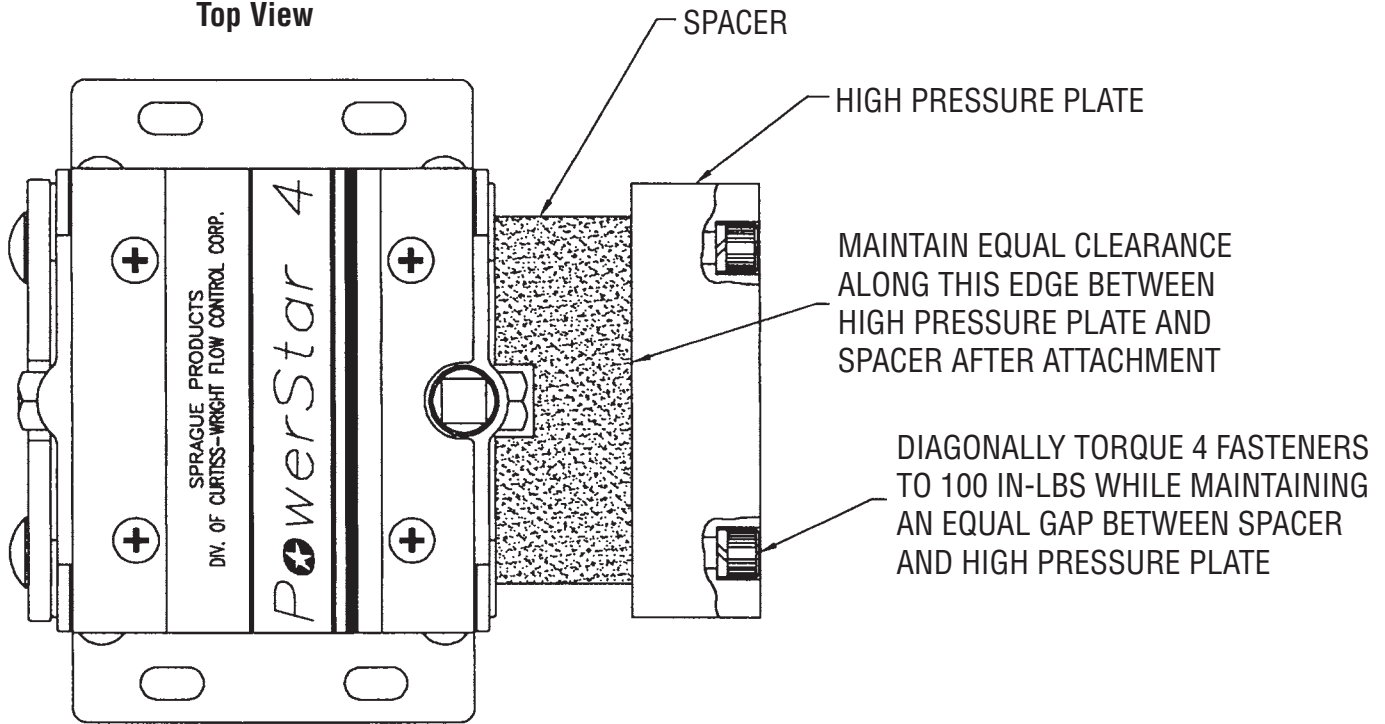

Side View

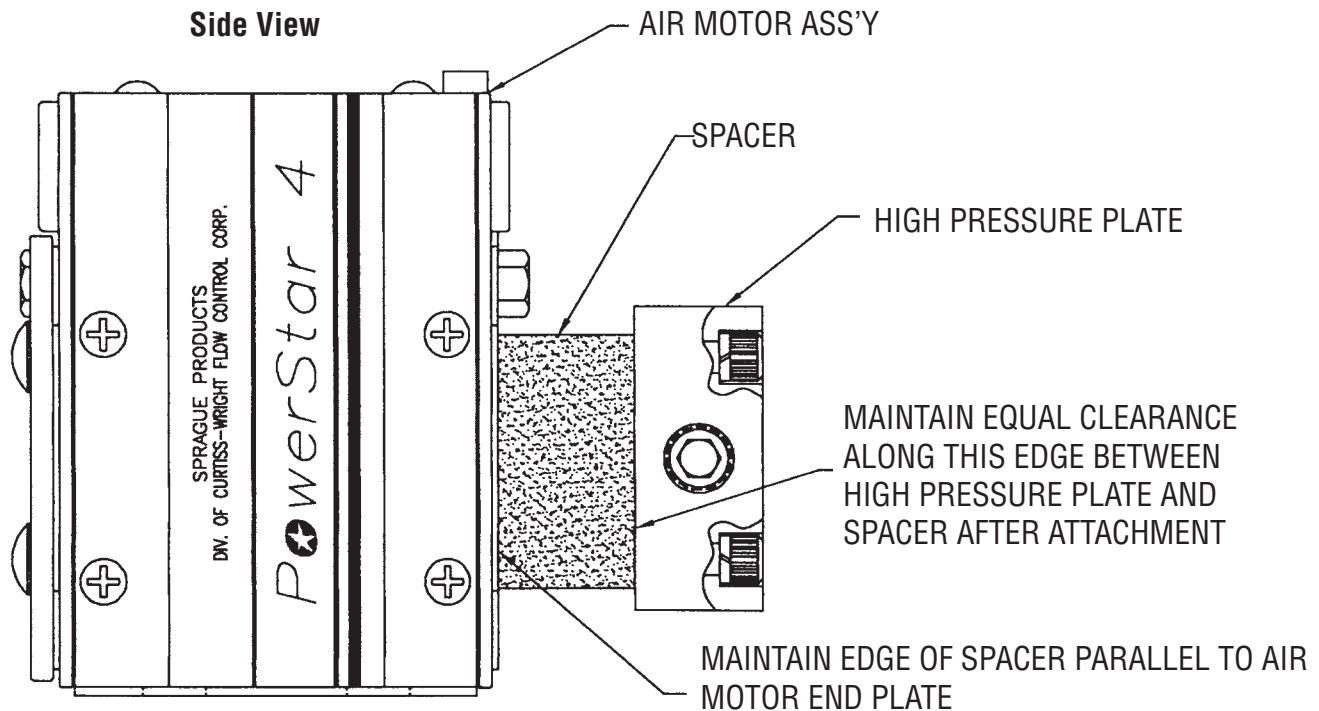

SEPARATOR KIT

Optional for single ended pump.
Required for double ended pump.

SPECIAL SEPARATOR KITS

FOR SEPARATORS USING DIFFERENT
O-RING COMPOUNDS (NOW NITRILE)
USE THE FOLLOWING DESIGNATIONS.

PART NO. O-RING COMPOUND

4SK (RATIO) - NITRILE

4SK (RATIO) E - EPR

4SK (RATIO) V - VITON

4SK (RATIO) N - NEOPRENE

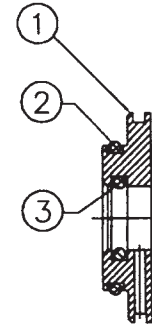
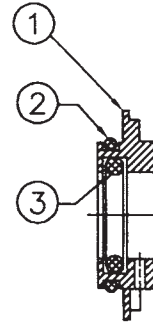
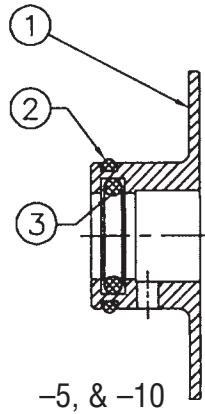

-5, & -10

-21, -34 & -64

-114, -203 & -333

DASH NO.	ITEM NO.	DESCRIPTION	PART NUMBER	QTY	CATALOG PART NO.
93728-333	3	O-RING NITRILE 90SH	79550-4-1	1	4SK333
	2	O-RING NITRILE 70SH	91417-018	1	
	1	RETAINER, SEPARATOR	93725-333	1	
93728-203	3	O-RING NITRILE 90SH	93731	1	4SK203
	2	O-RING NITRILE 70SH	91417-018	1	
	1	RETAINER, SEPARATOR	93725-203	1	
93728-114	3	O-RING NITRILE 90SH	79550-7-1	1	4SK114
	2	O-RING NITRILE 70SH	91417-018	1	
	1	RETAINER, SEPARATOR	93725-114	1	
93728-64	3	O-RING NITRILE 90SH	93969	1	4SK64
93728-34	2	O-RING NITRILE 70SH	79550-10-1	1	4SK34
	1	RETAINER, SEPARATOR	91417-018	1	
93728-21			93724	1	4SK21
93728-10					4SK10
	3	O-RING NITRILE 90SH	79550-10-1	1	
	2	O-RING NITRILE 70SH	91417-018	1	
93728-10	1	RETAINER, SEPARATOR	93729	1	4SK5

INSTALLATION OF SEPARATOR KITS

INSTRUCTIONS

1. For Kits 4SK5, 4SK10, 4SK21, 4SK34, and 4SK64: Slide liquid piston rod (45) through separator as shown in Fig. 1.
2. For Kits 4SK114, 4SK203, and 4SK333: Slide separator on liquid piston rod (45) as shown in Fig. 2.
3. Seal retainer or spacer (43) is not used when a separator is installed.
4. Carefully push separator into bore of air motor endplate, making sure that vent holes in the separator and air motor endplate are aligned. See Typical Installation Views below.
5. Remove Allen head plug (13) from bottom of air motor endplate.
6. Complete balance of assembly procedure as outlined in steps 7.10 through 7.16 on pages 9 and 10.

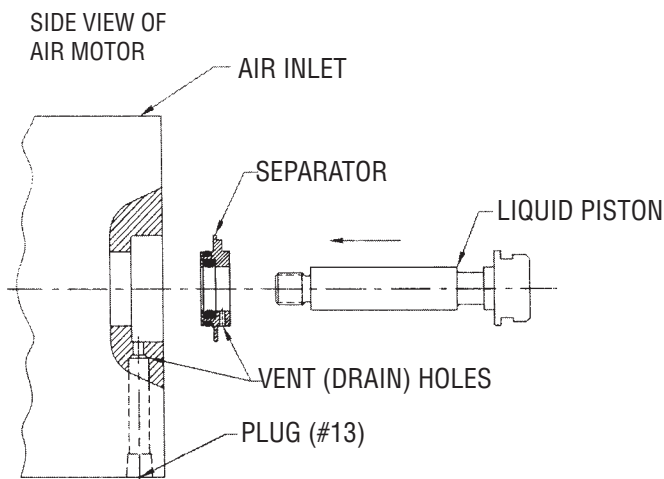

FIG. 1:
KITS #4SK5, 4SK10
4SK21, 4SK34, & 4SK64

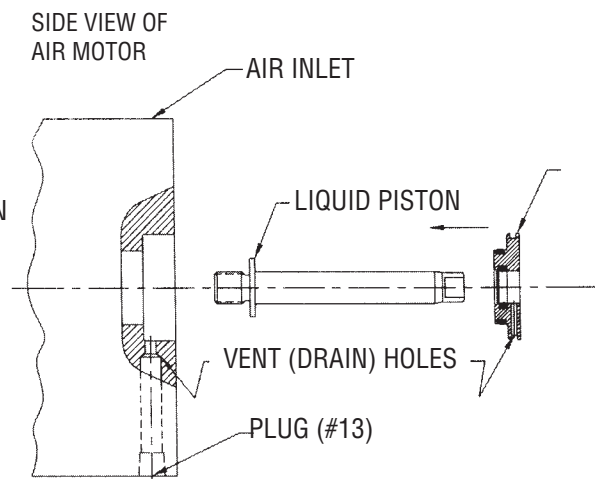
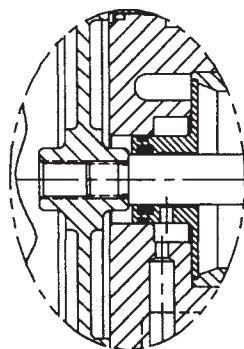
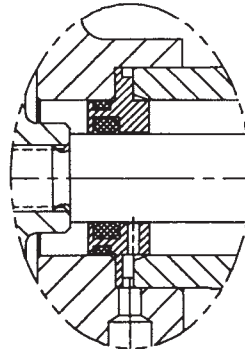

FIG. 2:
KITS #4SK114, 4SK203 & 4SK333

TYPICAL INSTALLATION VIEWS



-5, & -10



-21, -34 & -64

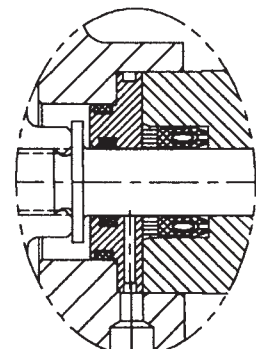

-114, -203 & -333

AIR MOTOR P4

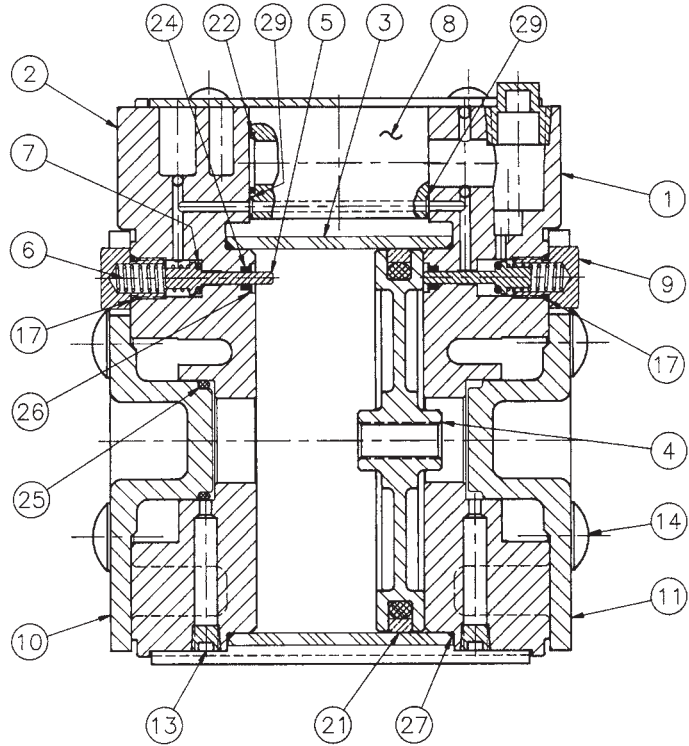

MODULAR PUMP ASSEMBLY TOP VIEW

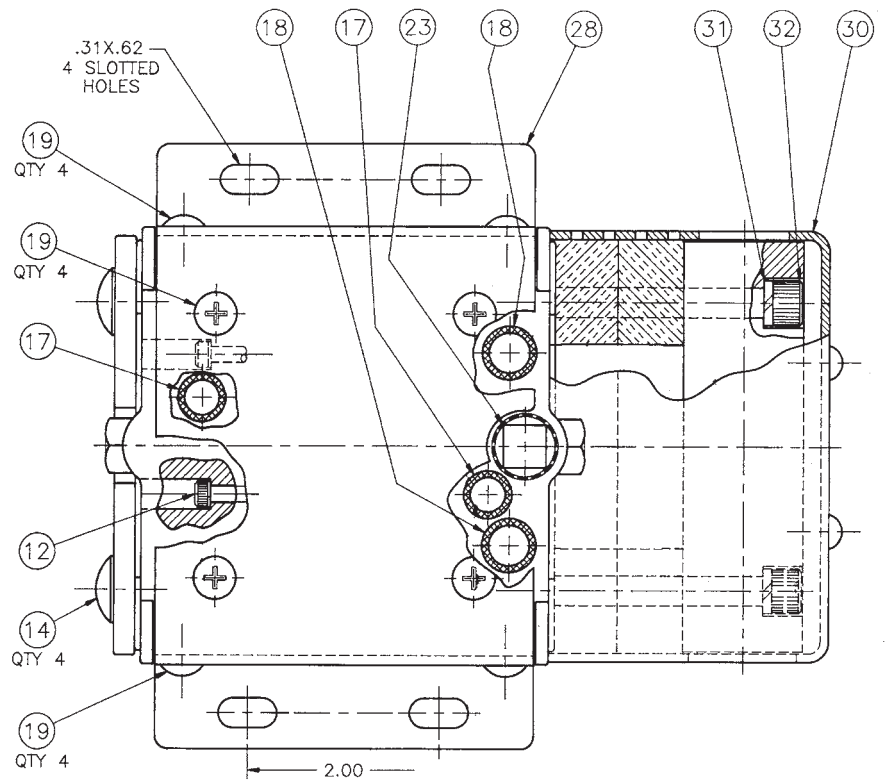

ITEM NO.	PART NUMBER	DESCRIPTION	QTY
1	93654	END PLATE, AIR	1
2	93656	END PLATE	1
3	93666	CYLINDER, AIR	1
4	93658	AIR PISTON	1
5	93668	PISTON, PILOT VALVE	2
6	93697	SPRING	2
7	79550-2-1	O-RING NITRILE 90SH .145" I.D.	2
8	93667	AIR VALVE ASSEMBLY	1
9	93669	PLUG, PILOT VALVE	2
10	93670-1	PLUG, AIR MOTOR	1
11	93670-2	PLUG, AIR MOTOR	1
12	92124-03D20X	SOC/HD #8-32 X 2.50" LG.	2
13	93694	PLUG, HOLLOW HEX. 1/16"-27	2
14	92124-07N06C	TRUSS HD. PHILLIPS 5/16"-18 X 3/4" LG.	6
15	92124-07D30Z	SOC/HD 5/16"-18 X 3.75" LG.	4
16	94006-.312-18	HEX NUT 5/16"-18 SELF LCK.	4
17	91417-012	O-RING NITRILE 70SH .364" I.D.	4
18	91417-013	O-RING NITRILE 70SH .426" I.D.	2
19	92124-04N03C	TRUSS HD. PHILLIPS #10-24 X 3/8" LG.	12
21	92507	SEAL SYSTEM	1
22	91417-014	O-RING NITRILE 70SH .489" I.D.	1
23	R 3/8	CAP PLUG 3/8" NPT	1
24	91417-006	O-RING NITRILE 70SH .114" I.D.	2
25	91417-121	O-RING NITRILE 70SH 1.049" I.D.	1
26	93695	PUSH ON RING 5005-31-H	2
27	91417-045	O-RING NITRILE 70SH 3.989" I.D.	2
28	93671	ENCLOSURE, MOTOR	1
29	93681	O-RING NITRILE 70SH .120" I.D.	2
30	93698	DECAL	1
31	93721	NAMEPLATE, AIR MOTOR	1
32	93723	DECAL, PATENT PENDING	1

**4F5, 4F10
SECTION A-A**

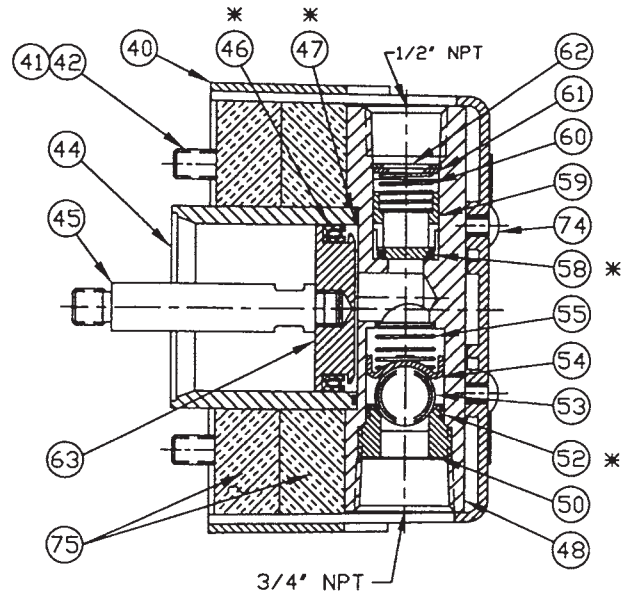

* Included in Overhaul Kit

ITEM NO.	PART NUMBER		DESCRIPTION	QTY
	4F5	4F10		
40	93688	93688	ENCLOSURE, MUFFLER	1
41	MS51848-11	MS51848-11	LOCK WASHER HI-COLLAR 5/16	4
42	92124-07D22Z	92124-07D22Z	SOC/HD 5/16"-18 X 2.75"	4
44	93921-5	93921-10	CYLINDER, HIGH PRESSURE	1
45	93676	93676	PISTON ROD	1
46	93685-14	93685-15	SEAL, PISTON	1
47	91417-032	91417-032	O-RING	1
48	93677	93677	PLATE, HIGH PRESSURE	1
50	93678	93678	SEAT, INLET CHECK VALVE	1
52	91417-017	91417-017	O-RING	1
53	93937	93937	BALL, CERAMIC, 5/8" DIA. GRADE 25	1
54	78621-7	78621-7	GUIDE, BALL	1
55	93700	93700	SPRING	1
58	79550-8-1	79550-8-1	O-RING	1
59	93807	93807	POPPET	1
60	S-216-63	S-216-63	SPRING, COMPRESSION, CHECK VALVE	1
61	93679	93679	WASHER	1
62	93696	93696	RETAINING RING	1
63	93680-5	93680-10	PISTON, HIGH PRESSURE	1
74	92124-04N04C	92124-04N04C	RD/HD PHILLIPS #10-24 X 1/2"	3
75	93683	93683	MUFFLER, MEDIA	2

**4F21, 4F34
SECTION A-A**

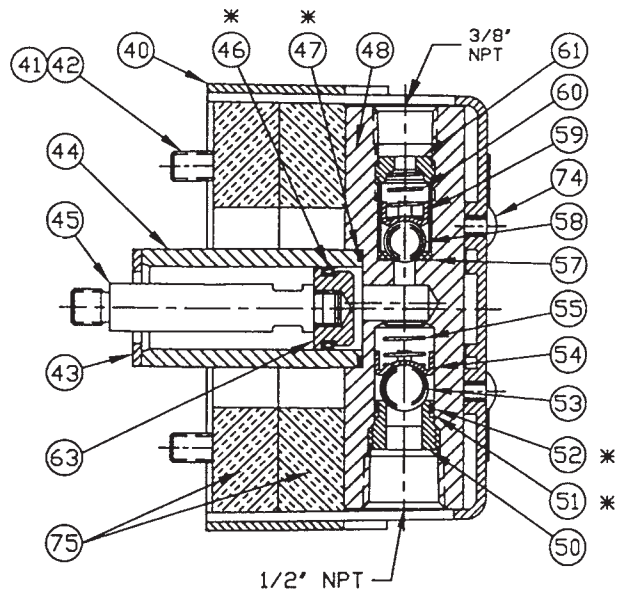

* Included in Overhaul Kit

ITEM NO.	PART NUMBER		DESCRIPTION	QTY
	4F21	4F34		
40	93688	93688	ENCLOSURE, MUFFLER	1
41	MS51848-11	MS51848-11	LOCK WASHER HI-COLLAR 5/16	4
42	92124-07D22Z	92124-07D22Z	SOC/HD 5/16"-18 X 2.75"	4
43	93711-21	93711-21	SPACER/RETAINER	1
44	93936	93945-34	CYLINDER, HIGH PRESSURE	1
45	93676	93676	PISTON ROD	1
46	93685-18	93685-19	SEAL, PISTON	1
47	91417-023	91417-019	O-RING	1
48	93691	93691	PLATE, HIGH PRESSURE	1
50	93690	93690	SEAT, INLET CHECK VALVE	1
51	91420-014	91420-014	RING, BACK-UP	1
52	91417-014	91417-014	O-RING	1
53	89864C-.500	89864C-.500	BALL 1/2" DIA. GRADE 100	1
54	78621-5	78621-5	GUIDE, BALL	1
55	93709	93709	SPRING, COMPRESSION, CHECK VALVE	1
57	93713-1	93713-1	SEAT, SEMI SOFT O/L C.V.	1
58	89864C-.438	89864C-.438	BALL 7/16" DIA. GRADE 100	1
59	78621-2	78621-2	GUIDE, BALL	1
60	S-216-63	S-216-63	SPRING, COMPRESSION, CHECK VALVE	1
61	93710	93710	RETAINER O/L C.V.	1
63	93680-21	93680-34	PISTON, HIGH PRESSURE	1
74	92124-04N04C	92124-04N04C	RD/HD PHILLIPS #10-24 X 1/2"	3
75	93683	93683	MUFFLER, MEDIA	2

4F64
SECTION A-A

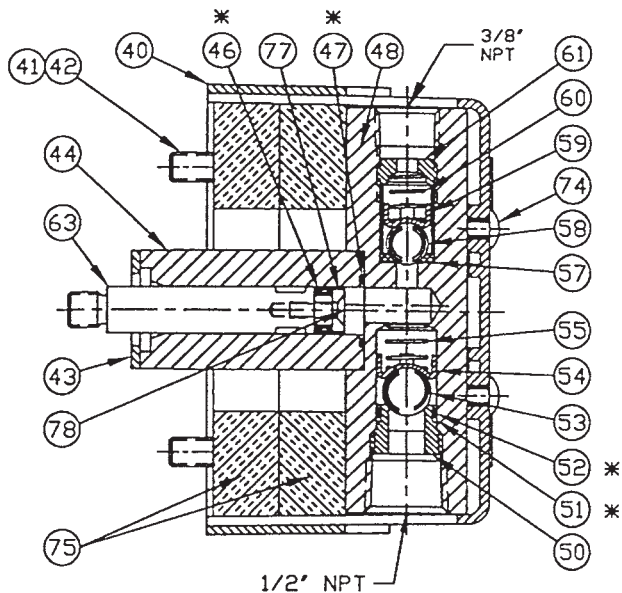

* Included in Overhaul Kit

ITEM NO.	PART NUMBER 4F64	DESCRIPTION	QTY
40	93688	ENCLOSURE, MUFFLER	1
41	MS51848-11	LOCK WASHER HI-COLLAR 5/16	4
42	92124-07D22Z	SOC/HD 5/16"-18 X 2.75"	4
43	93711-21	SPACER/RETAINER	1
44	93945-64	CYLINDER, HIGH PRESSURE	1
46	93685-20	SEAL, PISTON	1
47	91417-016	O-RING	1
48	93691	PLATE, HIGH PRESSURE	1
50	93690	SEAT, INLET CHECK VALVE	1
51	91420-014	RING, BACK-UP	1
52	91417-014	O-RING	1
53	89864C-.500	BALL 1/2" DIA. GRADE 100	1
54	78621-5	GUIDE, BALL	1
55	93709	SPRING, COMPRESSION, CHECK VALVE	1
57	93713-1	SEAT, SEMI SOFT O/L C.V.	1
58	89864C-.438	BALL 7/16" DIA. GRADE 100	1
59	78621-2	GUIDE, BALL	1
60	S-216-63	SPRING, COMPRESSION, CHECK VALVE	1
61	93710	RETAINER O/L C.V.	1
63	93946	PISTON, HIGH PRESSURE	1
74	92124-04N04C	RD/HD PHILLIPS #10-24 X 1/2"	3
75	93683	MUFFLER, MEDIA	2
77	93831-4	RETAINER, HIGH PRESSURE SEAL	1
78	MS24694-C5	SCREW, FLAT HD, #8-32 X 17/32"	1

4F114, 4F203, 4F333
SECTION A-A

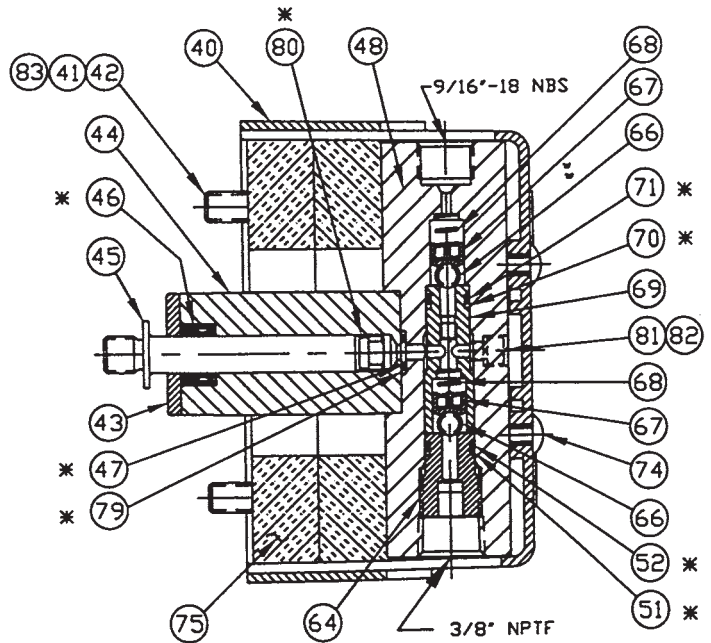

* Included in Overhaul Kit

ITEM NO.	PART NUMBER			DESCRIPTION	QTY
	4F114	4F203	4F333		
40	93688	93688	93688	ENCLOSURE, MUFFLER	1
41	531012-1012	531012-1012	531012-1012	WASHER, LOCK 5/16"	4
42	93833-2	93833-2	93833-2	STUD, SHOULDER	4
43	93711-114	93711-203	93711-333	SPACER/RETAINER	1
44	93954-114	93954-203	93954-333	CYLINDER, HIGH PRESSURE	1
45	93953-114	93953-203	93953-333	PISTON ROD	1
46	93685-21	93685-22	93685-23	SEAL, PISTON	1
47	91417-009-1	91417-009-1	91417-009-1	O-RING	1
48	93950	93950	93950	PLATE, HIGH PRESSURE	1
51	MS27595-012	MS27595-012	MS27595-012	BACKUP RING	2
52	91417-012-1	91417-012-1	91417-012-1	O-RING	2
64	93715	93715	93715	SEAT, INLET CHECK VALVE	1
66	89864C-.250	89864C-.250	89864C-.250	BALL, 1/4" DIA. GRADE 100	2
67	78621-6	78621-6	78621-6	GUIDE, BALL	2
68	93716	93716	93716	SPRING, COMPRESSION, CHECK VALVE	2
69	93951	93951	93951	SEAT, OUTLET CHECK VALVE	1
70	MS27595-011	MS27595-011	MS27595-011	BACKUP RING	1
71	91417-011-1	91417-011-1	91417-011-1	O-RING	1
74	92124-04N04C	92124-04N04C	92124-04N04C	SCREW, RD HD, PHILLIPS, #10-24 X 1/2"	3
75	93683	93683	93683	MUFFLER MEDIA	2
79	93803	93803	93803	BACKUP RING	1
80	93947-114	93947-203	93947-333	GUIDE, PISTON	1
81	92124-03D09Z	92124-03D09Z	92124-03D09Z	SCREW, SOC HD, #8-32 X 1.125" LG.	2
82	MS35338-137	MS35338-137	MS35338-137	WASHER, LOCK, SPRING, HELICAL, #8	2
83	516902-0012	516902-0012	516902-0012	NUT, HEX, HEAVY, 5/16-18	4



Sprague® Products

Division of Curtiss-Wright Flow Control Corporation

10195 Brecksville Road, Brecksville, Ohio 44141 • 440/838-7690 • FAX: 440/838-7513 • www.cwfc.com

Napoleon House, Gore Cross Business Park, Corbin Way, Bridport, Dorset DT6 3UX UK Tel: 44 (0) 1308 422256, Fax: 44 (0) 1308 427760

© Sprague Products 2006
Part No.: PS4HB-3M-0106