

DJ 'G9F=9G
 %%#&<D'5F'A C H C F
 GB; @9G5; 9'D@B9H5FMF98I 7 9F

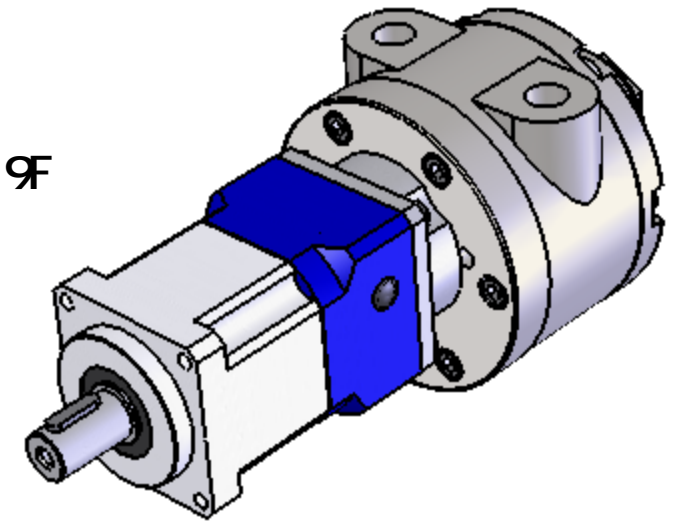

CI HDI HHC FE I 9

HCFE I 9ž'p! Vg

YUFFUJc
 A c h e f k # c ; Y U F f b [

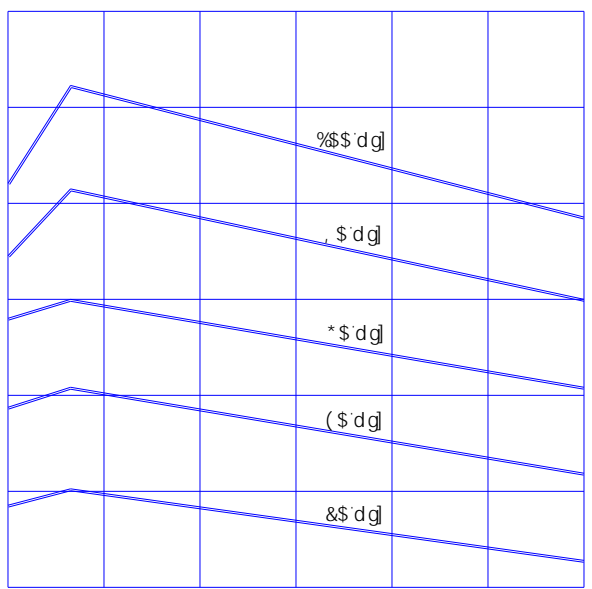

5F'7CBG A D H C B

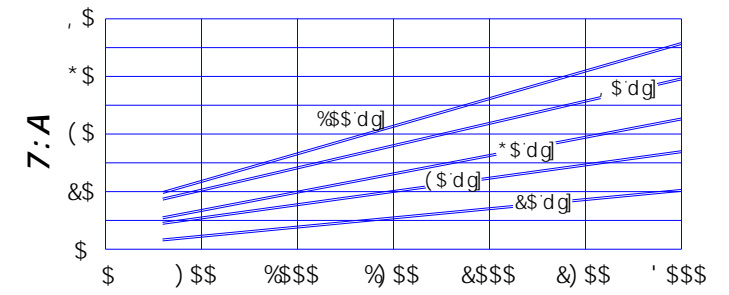

A C H C F 'GD998ž'fda

; 95F
 F5HC 2

A C H C F
 O K # k C I H
 ; 95F-B;

\$) \$\$ - %\$\$\$ - % \$ \$ - & \$\$\$ - &) \$ \$ - ' \$\$\$
 \$ % + - ' ' -) \$ \$ - * * + - , ' - % \$\$\$
 \$ - % \$ \$ - & \$ \$ - ' \$ \$ - (\$ \$ -) \$ \$ - * \$ \$
 \$ - + % - % (' - & % (- & ,) - ') + - (& -
 \$ -) \$ - % \$ \$ - % +) - & \$ \$ - &) \$ - ' \$ \$

GD998ž'fda

CI HDI HG<5: H@ 58-B; / ; 95FA C H C F K 9ž <HG	K #k: GB; @ G5; 9 F98I 7 9FG ' .98 %& %
5DDFC L"K 9ž <Hž Vg	%\$")
A 5L"F58-5@G<5: H@ 58ž Vg	' %
A 5L"5L-5@G<5: H@ 58ž Vg	% \$

2'C D9F 5H9G-B '5B MC F-9B H5 HC B
 2'@-9HA 9F98I 7 9F @ 6F-7 5HC B
 2'A C H C F F9E I F9G5F @B9@ 6F-7 5HC B

DJ '%%#&<Dž%G5; 9'D9F: C F A 5B7 9
 8K; "BC" %(-!%\$+ F9J \$%
 : Yf[i gc b9b[]bY Yf]b["Wc a fl \$) E(*% ' -&\$